

Battery and Connector Contacts

The Eccentric Plunger Probe is a new, spring contact probe design that allows product designers to use a much smaller probe with higher reliability and lower, more consistent resistance than ever before.

This product breakthrough centers on a patented design for the internal biasing of a probe in a much shorter probe package. As a result, IDI engineers have significantly improved the reliability and longevity of the probe by reducing resistance and probe wear. The customer also receives greater value through:

- Design flexibility
- Smaller packages
- Increased performance

Conventional spring loaded contact probes generally include an outer receptacle, a barrel containing a movable plunger and a spring, which exerts a force against the back of the plunger to “bias” the plunger against the barrel.

As products continue to shrink in size, many connector and semiconductor probe applications demand shorter and shorter overall lengths. In order to maintain enough spring cavity to provide acceptable stroke and spring force, it has become common to back-drill the plunger. With a back-drilled plunger, biasing through conventional techniques is no longer possible.

The Eccentric Plunger Probe design features a plunger with back-drilled hole or aperture with the centerline of the aperture slightly offset or nonparallel to the plunger’s longitudinal axis. By drilling the plunger’s spring cavity in an eccentric fashion to the centerline of the plunger, the spring induces lateral force that actually proves to be significantly superior to biasing in enforcing plunger to barrel contact.

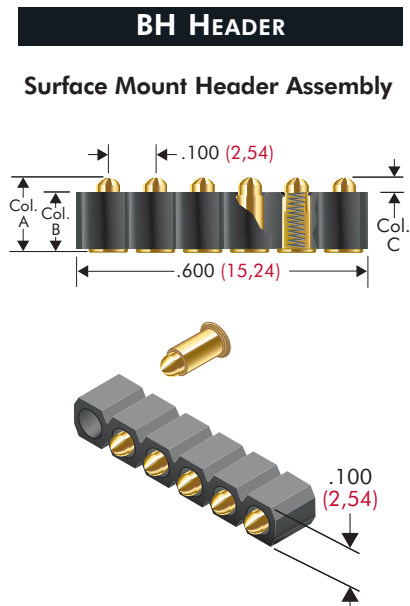
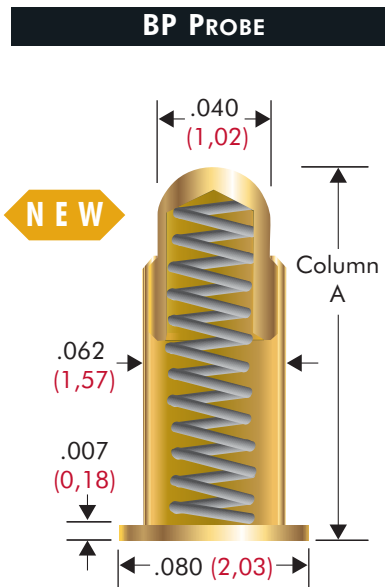

PROBE SPECIFICATIONS

Minimum Centers: .100 (2,54)
Current Rating: 12 amps continuous
 (Individual probe in free air; temp rise = 80° C)
Spring Force: 4.0 oz. @ Column C
Typical Resistance: <10 mΩ
Maximum Travel: Column C
Working Travel: Column C

Series	Column A Total Length	Column B Compressed Length	Column C Maximum Travel
BH-3	0.157 (4,00)	0.118 (3,00)	0.039 (1,00)
BH-6	0.315 (8,00)	0.236 (6,00)	0.078 (2,00)
BH-9	0.454 (11,50)	0.354 (9,00)	0.100 (2,54)

MATERIALS

Barrel: Brass, gold plated
Spring: Stainless steel, passivated
Plunger: Heat-treated beryllium copper, gold plated
Plastic Header: Thermx: black glass filled polyester
Special Feature: Patented eccentric drill, low resistance

HOW TO ORDER: LOOSE PROBE			ASSEMBLY		
BP	3		BH	3	6
SERIES	PROBE COMPRESSED LENGTH		SERIES	PROBE COMPRESSED LENGTH	CONTACTS PER HEADER
	3 – 3mm 6 – 6mm 9 – 9mm			3 – 3mm 6 – 6mm 9 – 9mm	6 MAXIMUM

Specifications subject to change. Dimensions in inches (millimeters)